

# 24 A

## Mailles rhomboïdales

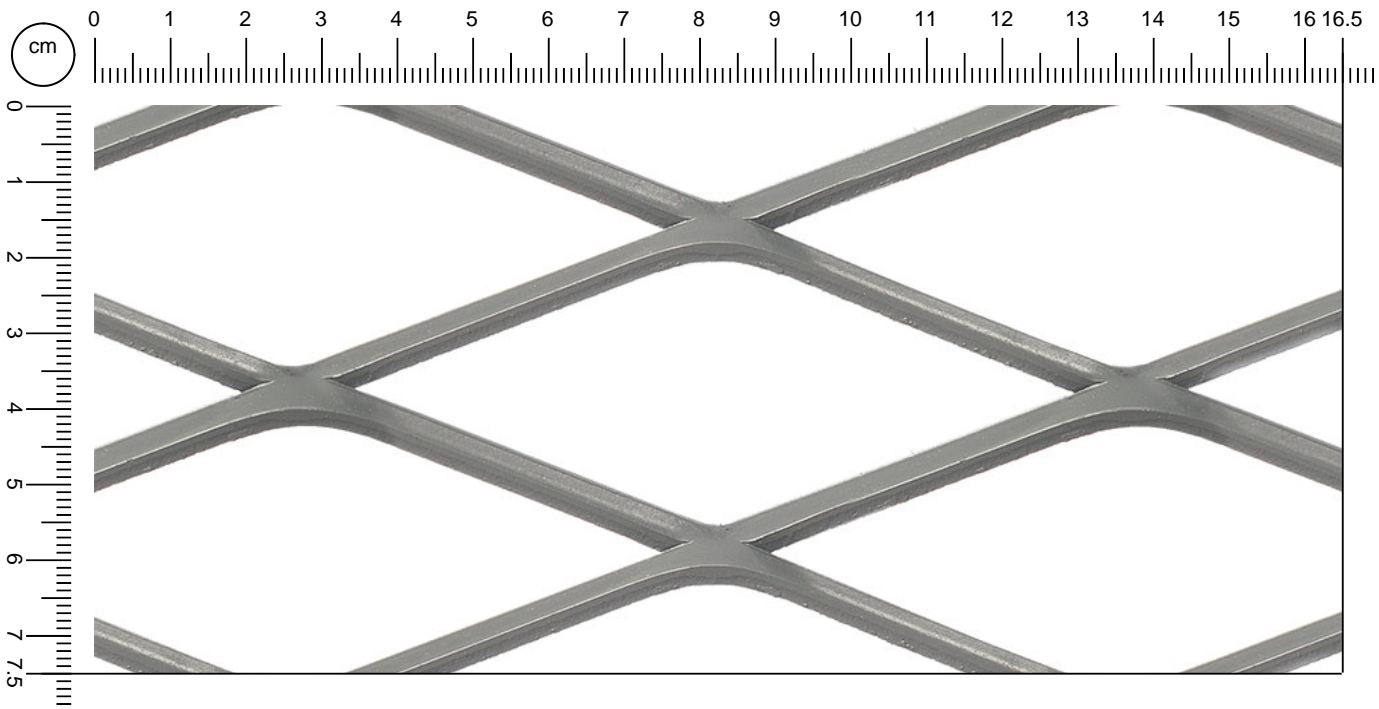

### Riferimenti

|           |  |
|-----------|--|
| Nome      | = Geom DL x DCn (DCr) - av x sp                      |
| Geom      | = Esagonale, Romboïdale, Quadra                      |
| DL        | = Diagonale Lunga                                    |
| DCn       | = Diagonale Corta nominale (riferimento interno)     |
| DCr       | = Diagonale Corta reale                              |
| av        | = Avanzamento  |
| sp        | = Spessore   |
| Larg - DL | = Larghezza in direzione DL                          |
| Lung - DC | = Lunghezza in direzione DC (direzione di stiratura) |

**Product**  
**R 110 x 4**

**Matériau**

Acier au c

### Dimensioni



### Dimensione maglia

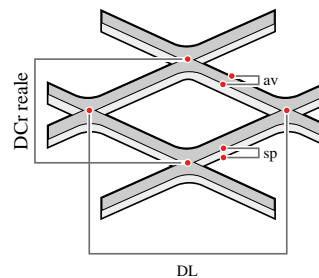

### Facciata a vista

