

## Mailles rhomboïdales

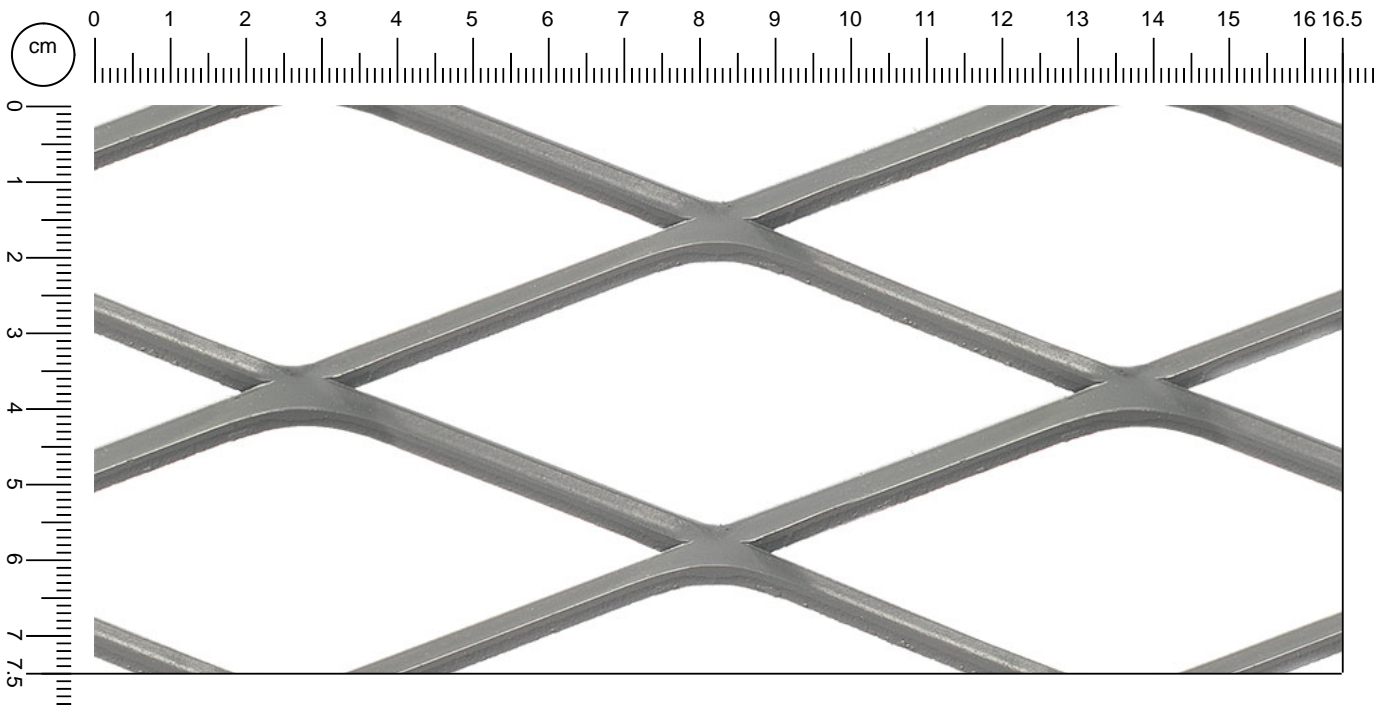

### Riferimenti

Nome	= Geom DL x DCn (DCr) - av x sp
Geom	= Esagonale, Romboïdale, Quadra
DL	= Diagonale Lunga
DCn	= Diagonale Corta nominale (riferimento interno)
DCr	= Diagonale Corta reale
av	= Avanzamento
sp	= Spessore
Larg - DL	= Larghezza in direzione DL
Lung - DC	= Lunghezza in direzione DC (direzione di stiratura)

**Product**  
**R 110 x 4**

**Matériau**

Acier au c

### Dimensioni

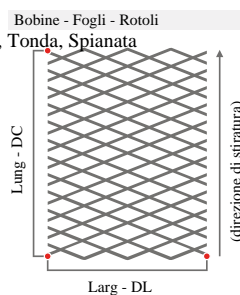

### Dimensione maglia



### Facciata a vista

